

Conical contact washer

Rondella conica contact Kontaktscheibe

TOOTHED - SN 70093

CARBON STEEL C 60 EN 10132

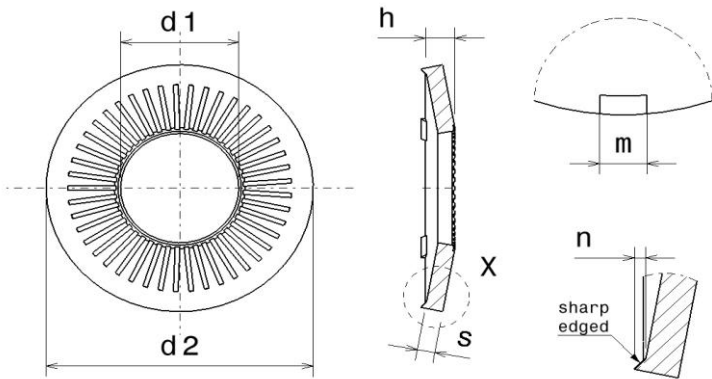

DIMENSIONS AND FEATURES										PACKAGING	
For screws of	d min.-max.	D min.-max.	s min.-max.	h min.-max.	n min.-max.	m min.-max.	No. of knurls	No. of teeth	Kg/1000 pieces	No. of pcs standard packaging	No. of pcs bulk packaging
M 3.0	3.10-3.35	5.80-6.20	0.57-0.63	0.80-0.95	0.10-0.30	0.70-0.90	28	6	0.081	2000	175000
M 4.0	4.10-4.40	7.80-8.20	0.77-0.83	1.00-1.15	0.20-0.40	1.10-1.30	32	6	0.200	2000	50000
M 5.0	5.10-5.40	9.80-10.20	0.97-1.03	1.25-1.50	0.30-0.70	1.90-2.10	36	6	0.410	1000	22000
M 6.0	6.10-6.40	11.80-12.20	1.16-1.24	1.50-1.80	0.30-0.70	2.00-2.20	45	6	0.710	1000	12000
M 8.0	8.20-8.56	15.80-16.20	1.36-1.44	1.95-2.40	0.30-0.70	2.00-2.20	45	6	1.500	1000	6500
M 10.0	10.20-10.56	19.75-20.25	1.56-1.64	2.15-2.60	0.30-0.70	2.00-2.20	45	6	2.680	1000	3500
M 12.0	12.40-12.80	23.75-24.25	1.56-1.64	2.15-2.60	0.30-0.70	2.00-2.20	45	6	3.850	500	3000
M 14.0	14.40-14.83	23.75-24.25	1.56-1.64	2.05-2.50	0.30-0.70	2.00-2.20	60	6	3.210	500	3000
M 16.0	16.40-16.80	31.70-32.30	2.44-2.56	3.50-3.95	0.30-0.70	4.50-4.70	60	6	10.900	100	1000
M 20.0	20.50-21.00	39.70-40.30	2.94-3.06	4.20-4.65	0.40-0.80	4.50-4.70	60	6	20.200	100	400

Dimensions in mm

Technical details:

Hardness: 420 - 510 Hv.
 Tightening couples: see table.
 Chemical analysis of raw material: see table.

Anticorrosion surface covering:

Burnishing and light oiling.
 White mech. zinc plating 12my Cr6 free.
 Yellow mech. zinc plating 12my Cr6 free.
 Delta Protokt® KL 100 6-10 my.
 Geomet® 321 type A 5-7 my.
 Other finishings by request.

Features and specific use:

Spring washer which has:
 - a round knurled ring with resistance to loosening on its contact surface with the screw's underhead.
 - a series of teeth on the surface in contact with the supporting field, which doesn't allow the rotation of the washer during the tightening.
 Recommended for electrical contact fasteners.