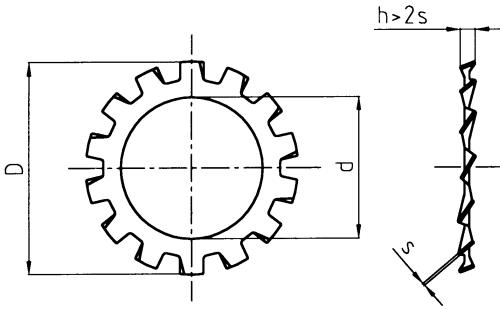

EXTERNAL TOOTHED DIN 6906
CARBON STEEL C 60 EN 10132

DIMENSIONS AND FEATURES						PACKAGING		
For screws of	d min.-max.	D min.-max.	s min.-max.	No. of teeth	Kg/1000 pieces	No. of pcs standard packaging	No. of pcs bulk packaging	No. of pcs micro packaging
M 2.5	2.25-2.35	5.32-5.50	0.36-0.44	6	0.045		170000	
M 3.0	2.70-2.80	5.82-6.00	0.36-0.44	6	0.050		160000	
M 3.5	3.20-3.32	6.78-7.00	0.46-0.54	6	0.080		100000	
M 4.0	3.60-3.72	7.78-8.00	0.46-0.54	8	0.100		60000	
M 5.0	4.55-4.67	8.78-9.00	0.55-0.65	8	0.167		40000	
M 6.0	5.50-5.57	10.73-11.00	0.65-0.75	8	0.220		25000	
M 8.0	7.40-7.55	13.73-14.00	0.75-0.85	8	0.400		12000	

Dimensions in mm

Technical details:

Hardness: 410 - 490 Hv.
 Tightening torques: see table.
 Chemical analysis of raw material: see table.
 Sorted out material to prevent the presence of foreign parts.

Anticorrosion surface treatment:

Dry and clean surface.
 Copper plating 3-4 my.

Features and specific use:

Washer to be used only for preassembling with metric pitch screws (for sems).